

# Occu-SmartStat

Digital learning thermostat with onboard occupancy and humidity sensors.

## Standard Features:

- Non-programmable self-scheduling thermostat with dehumidification
- Anticipates arrival but returns to setback when unoccupied
- Digital setpoint display
- Onboard occupancy sensor
- Onboard humidity sensor with onsite calibration
- Additional remote sensor inputs (for space temperature and/or occupancy)
- Occupancy based damper output
- Dehumidification control for both occupied and unoccupied modes
- Precise temperature control
- Configurable limits - comfort and economy
- Single speed fan control
- Configurable cycle rate, dead band, and system fan purge
- Backlighting
- Adaptive recovery
- 24-hour override feature keeps thermostat in occupied mode
- Diagnostic mode
- Key fob ready (for programming/configuration)
- Data logging
- Displays temperature in either Fahrenheit or Celsius



## Applications:

**Equipment:** Wall mounts, unit ventilators, vertical or horizontal geothermal heat pumps, other water source heat pumps, 2 or 4 pipe fan coils, PTACs, or PTHPs.

**Building Types:** schools, classrooms, portable classrooms, etc.

**Installation Considerations:** For installation on any interior wall surface. Thermostat should be located approximately 5 feet above the floor in an area with good air circulation. Activity used to qualify occupancy must be within view and range of occupancy sensor.

## Specifications:

Input Voltage:	24 VAC or 24 VDC
Load Rating:	1.0 amps max per circuit
Comfort Temperature	60°F to 85°F
Setpoint Range:	
Economy Temperature	Cool 72°F - 99°F;
Limits:	Heat 41°F - 72°F
Occupied Humidity Setpoint:	60% RH
Temperature Accuracy:	±1°F
Humidity Accuracy:	±3% typical, ±5% maximum
Backlight:	EL blue green
Occupancy Sensing:	Passive infrared, 39' typical
Case Material:	Polycarbonate, UL94-V0, white
Dimensions:	3.5"W x 5"H x 1.75"D

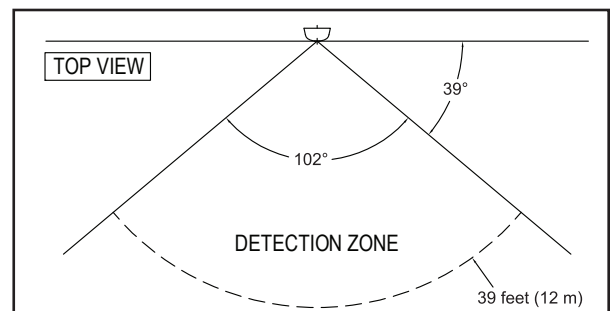

## Review Stamp:



Ph: 302-846-3747

### **Descriptive Specification:**

Temperature display shall be digital using an LCD, and the thermostat shall operate on 24 VAC or VDC. Setpoint only shall be displayed, but the ability to show actual temperature shall exist as a configurable option. Selection of the setpoint by the user shall be by clearly marked push buttons, and the setpoint range shall be 60°F to 85°F (15.5°C to 29.5°C). Limits shall be configurable via key entry or key fob data port. Control shall be battery free and maintain information in nonvolatile memory. Control shall hold last setting for a short period of power interruption and shall resume temperature based on occupancy status after longer periods of power interruption. The presence of the user shall be determined by an integral motion sensing device. Control shall anticipate arrival times based on occupancy patterns and will bring on heating or cooling to condition the space to the comfort setpoint accordingly (adaptive recovery). The control shall enter setback and checkout modes based on the absence of user after defined (configurable) periods of time. The rate of setpoint change during setback and checkout modes is also configurable, with preprogrammed profiles available. A temporary override feature shall be available, requiring a special button push and/or switch selection combination. Control shall sense relative humidity using an integral humidity sensor and shall enter dehumidification mode based on relative humidity. Control shall have separate occupied and unoccupied humidity setpoints. Damper opening (if connected) shall be based on occupancy status. All parameters have factory defaults which may be restored as needed. Load switching shall be with relays. Temperature droop shall be less than 1.0°F (0.5°C) at full rated load. Control shall have a diagnostic mode, which will alternately display setpoint, room temperature, and humidity. Altering of factory settings and diagnostic mode access shall be restricted by means of special codes. Control shall also have a data logging feature, with the most recent data (run times, temperature, humidity, etc.) retained in memory and downloadable via key fob programmer. The thermostat shall have the native ability to control wall mounts, unit ventilators, vertical or horizontal geothermal heat pumps, other water source heat pumps, 2 or 4 pipe fan coils, PTACs, or PTHPs through configuration.

### **Wiring:**

Notes: All wiring is the responsibility of the installer. The wiring diagrams shown are only typical. Detailed wiring diagrams will be outlined in the instructions.

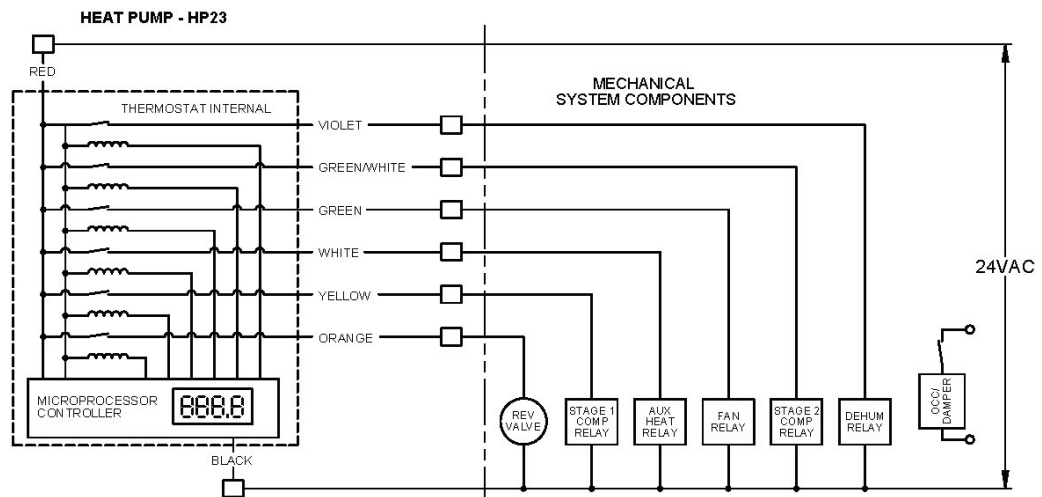

### **Model Selection:**

Model #	Voltage	System Changeover
<input type="checkbox"/> ICD-0614	24 VAC	Automatic

Backplate accessory  
(for retrofit applications)



### **Accessories:**

- ICD-BP-01 - Backplate (6"H x 6"W)
- ICD-KFP-01 - Key Fob Programmer

### **Warranty:**

Controls have a 1 year limited warranty against defects in workmanship and materials. (Contact us for full detailed warranty policy.)